

MUSTANG

MV-TILT2B



The Mustang MV-TILT2B is designed to be a sleek, sturdy, and secure solution for wall mounting your flat panel display. It provides lateral shift of the screen to compensate for off center wall studs as well as the added versatility of up to 15 degrees of tilt and lock adjustment. The MV-TILT2B is also a low profile mount, allowing you the beauty of your flat screen hanging on your wall without having the mount itself becoming a focal point. The simple design and VESA compatible mounting brackets allow for installation to be performed in minutes and will fit any display that conforms to industry standards.

DIMENSIONS:
20.67" x 8.86" x 2.95"

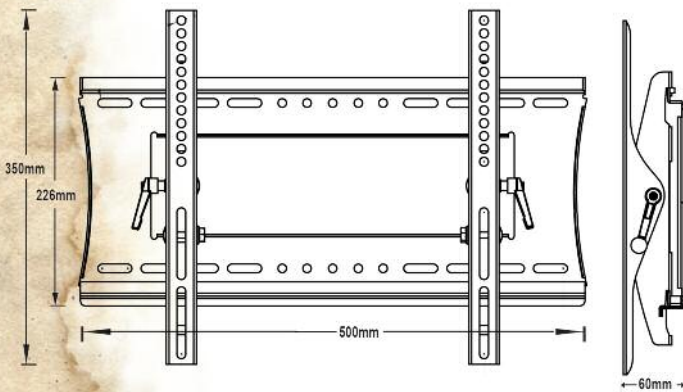

Features:

- Low Profile TILT Mount – 2.4" depth
- Recommended for use with MOST 23" to 40" flat panel displays
- VESA MAX hole pattern: 300mm x 470mm
- Max Load 100 lbs. (46 kgs)
- Tilt adjustment -5 / +15 degrees
- Slide lateral adjustment
- Includes mounting guide, locking system and complete hardware kit
- Installs in MINUTES with Lift-and-Hook design
- Anti-theft lock slot AND security bar
- Matte black finish

Hardware Kit



Coach Screw (x4)



Masonry Wall Plug (x4)



Small Spacer Bush (x4)



Multi Washer (x4)



Washer (x4)



Large Spacer Bush (x4)

Mounting Screws

Cross Recessed Screws



M8x15mm / M8x35mm / M8x45mm (x4 each)

M6x15mm / M6x35mm / M6x45mm (x4 each)

M5x15mm / M5x35mm / M5x45mm (x4 each)

M4x15mm / M4x35mm / M4x45mm (x4 each)

Tools Needed

- Power drill
- 10mm (3/8") or 6mm (1/4") drill bit
- Phillips head screw driver
- Spirit level
- 13mm (11/16") socket wrench or shifter

www.mustangav.com